

STOREFRONT & ENTRANCES



TUBELITE[®]
DEPENDABLE

LEADERS IN ECO-EFFICIENT STOREFRONT,
CURTAINWALL AND ENTRANCE SYSTEMS

TABLE OF CONTENTS

ENTRANCES	3
MODIFIED ENTRANCES.....	4
CUSTOM ENTRANCES	4
MONUMENTAL ENTRANCES	5
THERML=BLOCK ENTRANCES	5
14000 SERIES STOREFRONT	6
14000 I/O STOREFRONT	7
T24650/E24650	7
THERMAL TU24000	8
THERMAL TU24650	8
4500 SERIES STOREFRONT	9
INT45.....	9
VERSATHERM™ FRAMING.....	9
3700 SERIES WINDOWS.....	10
FINISHES - ANODIZED & PAINTED	11
FINISHES - WOOD GRAIN	11

Tubelite® has been in the business of fabricating and distributing architectural aluminum products for the glass and glazing industry since 1945. Storefront, entrance and curtainwall systems are available directly from Tubelite® and from a network of independent distributors. Tubelite's corporate office is located in Walker (Grand Rapids), Michigan, and our extrusion plant is in Reed City, Michigan. Fabrication, warehouse, and shipping operations are located in Walker, Michigan and Dallas, Texas. Tubelite also has remote sales offices in strategic geographic locations.

Our promise to you is quality in everything we do; fast, reliable and consistent delivery; and responsible, courteous service with a personal touch.

TUBELITE®

DEPENDABLE

LEADERS IN ECO-EFFICIENT STOREFRONT,
CURTAINWALL AND ENTRANCE SYSTEMS

800-866-2227 / www.tubeliteinc.com





*Standard Narrow Stile
1-3/4" x 2-1/8" Door with
10" Bottom Rail; 0A Clear
Anodized Finish; 1/4" Glass*

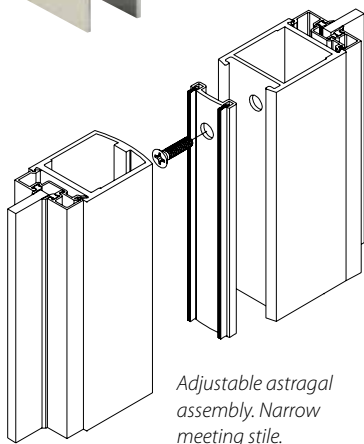

*Adjustable astragal
assembly. Narrow
meeting stile.*



Medium Stile Entrance

Standard Narrow Stile Entrances

Our Standard Narrow Stile Entrances are designed for light-to-moderate use in commercial applications. Standard Narrow Stile has 2-1/8" vertical stiles and top rail, and 4" bottom rail – optional up to 10" for ADA compliance. The smooth design of Tubelite's door hardware features a convenient pull handle and push bar with lock location 36" above the finished floor. Stock doors and frames are anodized with clear or dark bronze finishes, and readily available for quick delivery.

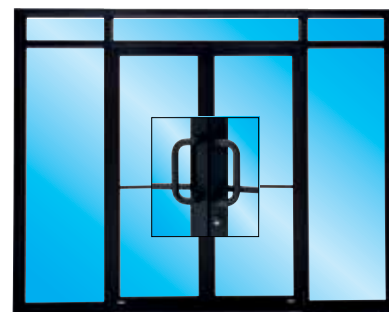

Standard Medium Stile Entrances

Our Standard Medium Entrances are designed for moderate to heavy use in commercial applications. Standard Medium Stile has 4" vertical stiles and top rail, and 6-1/2" bottom rail – optional up to 10" for ADA compliance. The smooth design of Tubelite's door hardware features a convenient pull handle and push bar with lock location 36" above the finished floor.

Standard Wide Stile Entrances

Our Stand Wide Stile Entrances are designed for moderate to heavy use in commercial applications. Standard Medium Stile has 5" vertical stiles and top rail, and 6-1/2" bottom rail – optional up to 10" for ADA compliance. The additional width of Medium and Wide stile doors provides greater durability, and allows application of a wider variety of operating hardware.

WE LISTEN

Members of our management staff personally visit our glazing contractor clients regularly. We learn what works and what doesn't — from their perspective, not ours. The result is solutions that work — solutions tailored for the field — so jobs get done right the first time.

Durable Tie-Rod Construction

The strength and flexibility of steel tie-rod construction is what holds it all together and makes our doors endure. Tie-rod assembly is as durable as welded corner construction, but superior in many ways. Tubelite doors can be modified, disassembled or resized right in the field. No other door offers you this much strength and flexibility.



Note: Dimensions do not include 1/2" glass stops.

Standard Entrance Series	Narrow Stile	Medium Stile	Wide Stile
Application	Offices, Strip Centers	Retail Stores	Public Buildings
Traffic	Light to Moderate	Moderate to Heavy	Heavy
Vertical Stile 1-3/4" x	2-1/8"	4"	5"
Top Rail 1-3/4" x	2-1/8"	4"	5"
Bottom Rail 1-3/4" x	4" (opt. up to 10")	6-1/2" (opt. up to 10")	6-1/2" (opt. up to 10")

Modified Entrances

Narrow, Medium and Wide Stile Doors can be anodized or painted in any of our standard finishes plus an infinite number of blendable standard and custom colors. A wide variety of specialized hardware can be applied, including butt hinges, offset or center pivots, push bars, pull handles, locks and cylinders. The simple addition of a snap-in glazing pocket in the doorframe allows you to easily incorporate sidelights. Horizontal or vertical mid-rails are available in widths from 1/2" to 10".



Modified Entrance; Military Blue Painted Finish; Project: RiverTown Crossings Mall; Grandville, MI; Architect: Dennis Goosen



*Modified Narrow Stile
1-3/4" x 2-1/8" Door with
4" Bottom Rail; BP Beige
Painted Finish, 1/4" Glass*

Custom Entrances

Automation, Speed, Accuracy, and Flexibility. Delivered at a Competitive Price! Tubelite custom entrances deliver a winning combination of expertise with special door hardware and superior quality craftsmanship and materials time after time. You can rely on our experience, close relationships with hardware suppliers, and state-of-the-art manufacturing to provide the best lead-time in the industry.



*Custom Entrance; Green Painted Finish;
Project: Youngstown State University Wellness Ctr; Youngstown, OH;
Architects: Strollo & Associates; General Contractor: Hively Construction*



Custom Entrance, Finish: Medium Bronze Ano; Project: The Cheesecake Factory; Columbus, OH; Architect: Architects Design Collaborative

Our product knowledge is your assurance that the order will be correct whether Tubelite fabricates to a template or installs the door hardware.

- Have the doors prepped only and apply the hardware yourself.
- Order the door hardware yourself and have us apply it.
- Let Tubelite do it all!

Monumental Entrances

Designed to withstand heavy use in high-traffic areas, Tubelite's Monumental Doors feature a section depth of 2" and minimum wall thickness of 3/16", increased at critical points to 1/4" for added strength. Available in Narrow Stile 3", Medium Stile 4-1/2" and Wide Stile 6" models; top rails in 3-1/2", 4-1/2" and 6" heights; and bottom rails in 6" or optional 10" heights for ADA compliance. Sight lines complement the bold features of institutional applications and heavy-duty hardware. Framing may be reinforced with steel and used with a continuous hinge for maximum strength and dependability.



Monumental Entrance, Finish: Clear Anodized; Project: Mansfield ISD Center Performing Arts; Mansfield, TX; Architect: Huckabee

Note: Dimensions do not include 1/2" glass stops.

Monumental Doors	Narrow Stile	Medium Stile	Wide Stile
Application	Schools, universities, hospitals, offices		
Traffic	Heavy		
Vertical Stile 2" x	3"	4-1/2"	6"
Top Rail 2" x	3-1/3"	4-1/2"	6"
Bottom Rail 2" x	6" (opt. up to 10")	6" (opt. up to 10")	6" (opt. up to 10")

ThermI=Block Entrances

ThermI=Block[®] HIGH-PERFORMANCE THERMAL FRAMING

Tubelite ThermI=Block Entrances are designed using the same durable components as our Standard Entrances for outstanding craftsmanship and strength, with the additional benefit of strut thermal barriers for enhanced thermal performance. Door stiles are available in Medium Stile 4" and Wide Stile 5" models; top rails in 4" and 5" heights; and bottom in 10" height for ADA compliance. Snap-in thermally broken vertical frame closures easily accommodate addition of sidelites and incorporation with thermal storefront framing.

ThermI=Block Entrances are furnished with mortised butt hinges, offset pivots or continuous hinges as specified. Standard deadbolt locks, and concealed vertical rod or rim panic exit devices also may be selected. Standard pull handles have been designed for ADA access and have matching push bars.



Tubelite thermal entrances use ThermI=Block to provide superior insulation through increased aluminum separation and air space, while also increasing strength and reducing stress.



ThermI=Block Thermal Entrances, Choice One Bank, Newaygo MI

14000 Series

For optimal strength and thermal performance, use Tubelite's 14000 Series Storefront Framing, a flush-glazed system for use on storefront and low-rise applications. Framing is available in standard non-thermal and thermal members with 2" x 4-1/2" profiles and a 1/2" bite for use with glass or panels up to 1-1/8" thick. Extra-heavy intermediate verticals are available for high performance against strong windloads.

Reduce project labor costs with the flexibility of inside or outside glazing. Members can be assembled using screw spline or clip joinery, and framing is compatible with Tubelite Narrow, Medium and Wide Stile Doors.

Our 14000 Series Storefront products are subjected to thorough testing by an independent laboratory, ensuring that you get the highest quality storefront framing products that the industry has to offer.



14000 Series Storefront; Finish: Hartford Green Paint; Project: Virtual Learning Academy; Berrien Springs, MI; General Contractor: Shelton Construction; Architect: CARMI Design Group

THE SOLUTION

Our goal is simple — to be the most dependable supplier in the architectural aluminum industry. This means quality products; fast, reliable delivery; and ease of fabrication and installation. Tubelite has built its business around this goal.



14000 Series Storefront; Finish: Dark Bronze Anodized; Project: Wendy's; Cemetery Road, Hilliard, OH; Architect: In-House



14000 Series Product Specifications

See Tubelite's Test Reports for mock up sizes and test conditions.

Application: Low-rise commercial buildings: retail, office, healthcare, schools, etc.

Description: 2" x 4-1/2" center set, outside or inside flush glazed storefront.

Face Width:	System Depth:	Glass:	Air Infiltration:	Water Infiltration:	Structural:	U-Value:	CRF:	Acoustic:
2"	4-1/2"	1" std (1/8" – 1-1/8")	0.06 CFM/Ft.2 @ 6.24 PSF	10 PSF – Static 10 PSF – Dynamic	30 PSF – Design 45 PSF – Overload	Slot – 0.39 P&D – 0.33	Slot – Frame 54 Glass 61 P&D – Frame 62 Glass 68	STC 32 OITC 26

14000 I/O Series

Glass or panels can be positioned to the inboard (I) or outboard (O) side of the 4-1/2" depth frame to achieve the look you imagine. Typical glass thickness is 1", and can be installed from the outside or inside of the building. Special glazing pocket reducers allow the use of 1/4" infill thicknesses, too.

14000 I/O Series Multiplane Storefront Framing thermal barrier insulates exterior surfaces from the interior to minimize temperature transfer. This provides industry accepted performance for condensation resistance and energy performance.

Using the same design, assembly, and accessories as the 14000 center glazed system allows combining inboard, outboard and center planes of glass in the same elevation with the same great performance.



14000 I/O Series Storefront; Project: Sandy Commerce Par; Sandy, UT; Architect: Babcock Design; General Contractor: Jacobsen Construction

14000 I/O Series Product Specifications

See Tubelite's Test Reports for mock up sizes and test conditions.

Application: Low-rise commercial buildings: retail, office, healthcare, schools, etc.

Description: 2" x 4-1/2" multiplane outside or inside flush glazed storefront.

Face Width:	System Depth:	Glass:	Air Infiltration:	Water Infiltration:	Structural:	U-Value:	CRF:	Acoustic:
2"	4-1/2"	1" std (1/8" – 1-1/8")	0.06 CFM/Ft.2 @ 6.24 PSF	10 PSF – Inside Plane 12 PSF – Outside Plane	30 PSF – Design 45 PSF – Overload	Inside – 0.33 Outside – 0.35	Inside – Frame 52 Glass 61 Outside – Frame 67 Glass 69	STC 32 OITC 26

T24650/E24650 Series

A new look for a timeless design. T24650 Series Storefront Framing has the same design, assembly and accessories as the 14000 center glazed system's 2" face with a 6-1/2" depth. This additional 2" depth on the interior side of the frame provides greater structural properties and allows taller first floor openings. The wider profile also cuts a distinctive image for a storefront that stands out from the crowd.

T24650 Series provides industry-accepted performance for CRF (condensation resistance) and U_c (conduction), using the same thermal barrier as the 14000 and 14000 I/O systems.



T24650 Series Storefront; Finish: 0A Clear Anodized; Project: HH Gregg Easton; Columbus, OH; Architect: Herschman; General Contractor: Corna Kokosing

T24650 Series Product Specifications

See Tubelite's Test Reports for mock up sizes and test conditions.

Application: Medium-Rise storefront, front set glass, outside glazed.

Description: 2" x 6-1/2" outside or inside flush glazed storefront.

Face Width:	Overall Depths:	Glass Thickness:	Air Infiltration:	Water Infiltration:	Structural:	U-Value:	CRF:	Acoustic:	Outside HVHZ Approved:
2"	6-1/2"	1" std.	0.06 CFM/Ft.2 @ 6.24 PSF	12 PSF – Static 12 PSF – Dynamic	30 PSF – Design 45 PSF – Overload	0.35	Frame 72 Glass 72	31 STC 25 OITC	YES FL# 20393.1

Thermal TU24000 Series

TU24000 Series; Project: Baker Center;
Minneapolis, MN; Architect: RSP Architects



Tubelite's most popular thermally broken storefront line has been expanded and enhanced with an additional P&D thermal break. The TU24000 Series has the same 2" x 4-1/2" profile as the T14000 system, and offers standard screw-spline or shear block connections.

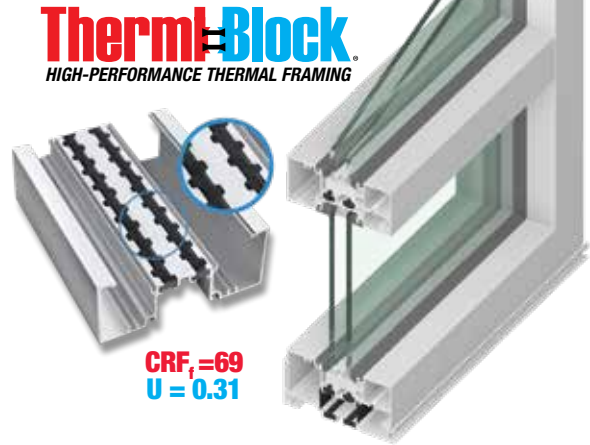

The dual thermal break improves U-Factor by 16% and increases CRF by 30% over a single P&D pocket when using the same size and type of insulated glass. Azon's Lancer® mechanical lock provides long-term resistance to shrinkage of the polyurethane barrier. Glass is centered in the 4-1/2" system depth for a pleasing reveal on the exterior and interior sides of the frame. Seven anodized finishes and 20 standard paint color are available to complement any project with warranted protection, as well as street appeal.

TU24000 Series Product Specifications

See Tubelite's Test Reports for mock up sizes and test conditions.

Application: Low and mid-rise commercial buildings requiring high energy and condensation resistance performance.

Description: 2" x 4-1/2" dual thermal barrier center set storefront system, screw spline or shear block connections, exterior or interior glazed.

Face Width:	Overall Depths:	Glass:	Air Infiltration:	Water Infiltration:	Structural:	U-Value:	CRF:	Acoustic:
2"	4-1/2"	1" std. (1/8" to 1-1/8")	0.06 CFM/Ft.2 @ 6.24 PSF	12 PSF – Static 12 PSF – Dynamic	30 PSF – Design 45 PSF – Overload	0.31	Frame 69 Glass 68	37 STC 31 OITC

Thermal TU24650 Series

Tubelite's dual thermally broken storefront line has been expanded and enhanced with the addition of TU24650 Series 2" x 6-1/2".

The dual thermal break decreases U-Factors and increases CRF over a single P&D pocket when using the same size and type of insulated glass. Azon's Lancer® mechanical lock provides long-term resistance to shrinkage of the polyurethane barrier. The glass plane matches that of our 4-1/2" system depth for a pleasing reveal on the exterior and interior sides of the frame. Seven anodized finishes and 20 standard paint color are available on this storefront framing system to complement any project with warranted protection, as well as street appeal.



TU24650 Series Product Specifications

See Tubelite's Test Reports for mock up sizes and test conditions.

Application: Low-Rise storefront, center set glass, inside/outside glazed.

Face Width:	Overall Depths:	Glass Thickness:	Air Infiltration:	Dynamic Water:	Structural:	U-Value:	CRF:	Acoustic:	Outside HVHZ Approved:
2"	6-1/2"	1" std.	0.06 CFM/Ft.2 @ 6.24 PSF	12 PSF	30 PSF – Design 45 PSF – Overload	0.32	Frame 75 Glass 70	31 STC 25 OITC	YES FL# 20393.1

4500 Series

Our 4500 Series Storefront framing is ideal for a wide variety of interior or low-rise exterior applications. Profiles of 1-3/4" x 4-1/2" are designed for 1/4" to 3/8" exterior glazing, and can be assembled by screw spline or clip joinery. The roll-in gasket is easy to install at the interior and exterior of the glass. The 1-3/4" framing is compatible with Tubelite Narrow, Medium and Wide Stile Doors.



INT45

INT45 Interior Flush Glaze Framing allows easy incorporation of standard aluminum storefront with metal stud and drywall systems commonly used in commercial office and retail space. Multiple adapters are available in configurations for installing the aluminum frames either before or after the drywall, completely covering the end of the stud wall. Installation is simple and fast with perimeter trim members that are pre applied on one side of the frame opening.

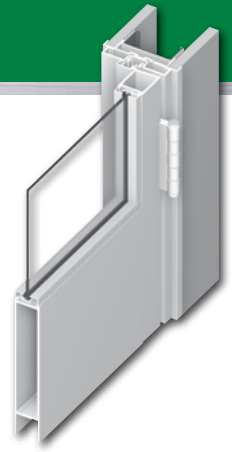

Standard swing doors and frames provide a complete system and come in 7 anodized and 20 standard painted finishes. Gaskets for glass thicknesses from 1/4" to 1/2" are available in Black or Grey as desired. There is also an option for use of recycled aluminum on the storefront members [excludes doors and door frames].

4500 Series Product Specifications

See Tubelite's Test Reports for mock up sizes and test conditions.

Application: Low and mid-rise commercial buildings including retail, office, healthcare, schools, etc.

Description: 1-3/4" x 4-1/2" center set, screw spline or shear block construction non thermal storefront field glazed, shear block construction storefront.

Face Width:	Overall Depths:	Glass:	Air Infiltration:	Water Infiltration:	Structural:	Acoustic:
1-3/4"	4-1/2"	1/4" std. (3/16" to 3/8")	0.06 CFM/Ft.2 @ 6.24 PSF	12 PSF - Static 12 PSF - Dynamic	30 PSF - Design 45 PSF - Overload	28 STC 27 OITC

VersaTherm™ Framing

VersaTherm™ Storefront Framing is our most versatile and economical storefront framing system. The flexible design allows for on-site fabrication in applications ranging from punched openings to mall fronts. VersaTherm is available in a large selection of profiles. Snap-on covers and backmembers, available in a variety of colors, allow for contrasting interior and exterior finishes. Finish options and glass positioning from frame exterior to center meet a wide range of aesthetic requirements.

Snap-on covers and back members are "locked" together by a unique thermal barrier clip. This clip ensures that interior and exterior metal members remain separate while firmly connected, virtually eliminating the transference of frost and condensation. High-performance verticals and compatibility with Tubelite stock doors create a complete and truly versatile system.

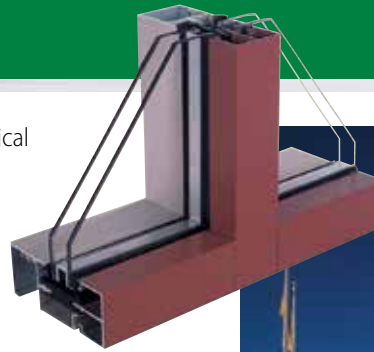

VersaTherm™ Series Product Specifications

See Tubelite's Test Reports for mock up sizes and test conditions.

Application: Low and mid-rise commercial buildings including retail, office, healthcare, schools, etc.

Description: 1-3/4" x (3-1/2" to 6-5/8") field glazed, shear block – screw spline storefront.

Face Width:	Overall Depths:	Glass:	Air Infiltration:	Water Infiltration:	Structural:	U-Value:	CRF:
1-3/4"	3-1/2" to 6-5/8"	1" std. (1/4")	0.06 CFM/Ft.2 @ 6.24 PSF	12 – Static	40 PSF – Design	0.36	Frame 64 Glass 55

3700 Windows

Let fresh air into the building through a storefront or curtainwall. 3700 Series windows can be easily incorporated with Tubelite's other framing systems. Special glazing pocket adapters make installation a breeze.

These Curtainwall rated windows have a frame depth of 2" with a maximum size of 3'0" x 5'0" and mitred corners epoxied and crimped on an "L" shaped clip.

Standard and concealed project-out vent design, and casement options are available. The concealed vent design is virtually invisible from the outside of the building, with no visible frame. Screens are also available with frames finished to match the window.

VW 3700



CW 3700



CVW 3700

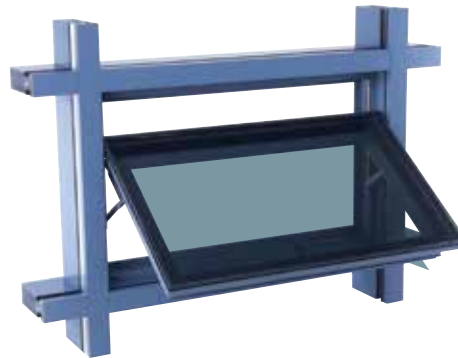

3700 Series Windows	VW3700	CVW3700	CW3700
Application	Conventional Frame	Concealed Vent	Casement Type
Frame Joints	Screw-spline	Screw-spline	Screw-spline
Window Joints	Mitered, 2 Corner Keys, Lanced Stake & Silicone	Mitered, 2 Corner Keys, Lanced Stake & Silicone	Mitered, 2 Corner Keys, Lanced Stake & Silicone
Glass Thickness	1/4" & 1"	1"	1/4" & 1"
Face Width	2-3/8"	-	2-3/8"
Frame Depth	2"	3-1/2"	2"
Hardware	4-bar hinges, Cam lock	4-bar hinges, Cam lock	Butt hinges, Cam lock, optional roto operator, 2-point egress lock, opening restrictor, egress pull-ring
Air Infiltration	0.10CFM/Ft.2 @ 6.24 PSF	0.10CFM/Ft.2 @ 6.24 PSF	0.10CFM/Ft.2 @ 6.24 PSF
Static Water	12 PSF	12 PSF	12 PSF
AAMA/WDMA/CSA 101 I.5.2/A440-08, NAFS Testing	CLASS CW-PG75 (60X36)-AP	CLASS CW-PG75 (61X38)-AP	CLASS CW-PG60 (36X60)-AP
Life Cycle Tested	2500 Cycles	2500 Cycles	2500 Cycles
CRF (AAMA 1503-2010)	56 _r / 67 _c	51 _r / 64 _c	59 _r / 68 _c
U-Factor	0.47	0.56	0.46
Florida Approval (Non-Impact)	FL15420	FL15420	FL15421

Finishes - Painted and Anodized



*Custom Entrance/400 Series Curtainwall,
Wild Grape 70% premium painted finish;
Project: Sun Healthcare; Albuquerque, NM;
Architect: Flatow-Moore-Shaffer-McCabe Inc.*

In addition to our standard Clear and Bronze anodized, and White painted colors, we offer five more anodized finishes and nineteen more standard painted colors. Blended standard and custom colors are also available, providing you with an infinite variety. More than a palette of pretty colors, our finishes are tough and backed by some of the best warranties in the industry.

See Tubelite's Standard Finish Color Guide for detailed information on the exceptional performance, integrity and weatherability of our durable anodized finishes. This guide also gives specifications for color retention, erosion resistance and gloss retention of our high-quality, painted finishes.

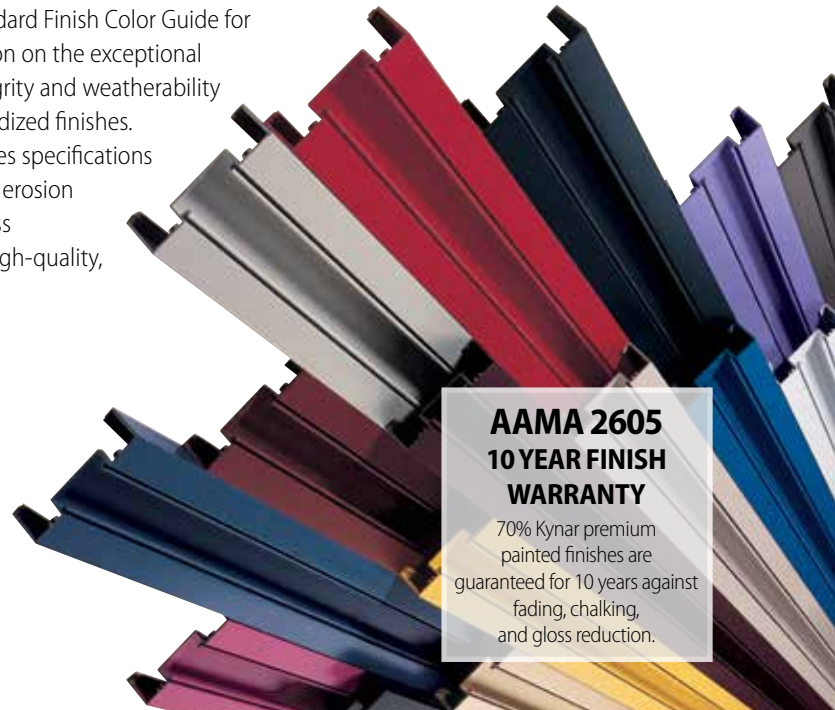

**AAMA 2605
10 YEAR FINISH
WARRANTY**
70% Kynar premium painted finishes are guaranteed for 10 years against fading, chalking, and gloss reduction.

Finishes - Wood Grain

When your design requires more than a stock color, our wood grain textures are ready to dazzle. Wood Grain Finishes by Tubelite have the look and feel of natural wood with the durability and recyclability of aluminum. No more refinishing due to salt, dirt and UV exposure. Our Wood Grain finishes are designed for the toughest environment and clean easily with mild soap and water.

Wood Grain Finishes by Tubelite can be applied to the interior and exterior of Tubelite's storefront, entrance, curtainwall, sunshade and light shelf devices. Practically everything we manufacture in the Tubelite family of products.

Tubelite offers the look and feel of natural wood with 12 Wood Grain Finishes. These finishes are backed by up to a 5 year warranty.

* Finishes may vary in tone and color within the same wood grain.

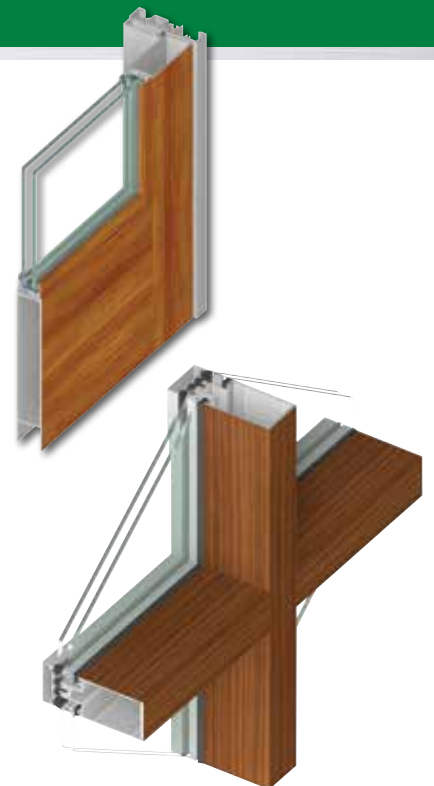

Visit www.tubeliteinc.com/finishes for all the latest finishes.

Visit us online to download other Tubelite literature at www.tubeliteinc.com/product-brochures.

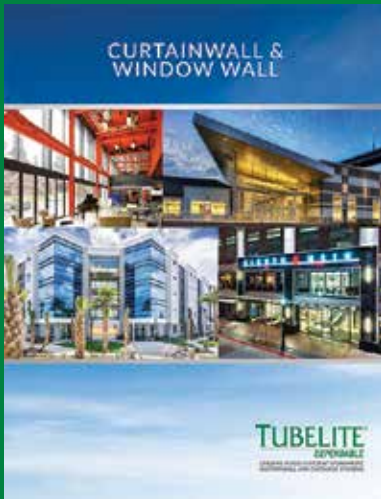

Curtainwall & Window Wall Product Brochure

This brochure contains our 400 Series Curtainwall, 200 Series Curtainwall, 900RW Series Thermal Ribbon Window, TerraPorte 7600 Terrace Door, Phantom 5000 Zero Sight Line Windows and Finishes.



High Performance Thermal Framing

Tubelite Thermi-Block – is a full line of high performance thermal framing that provides superior insulation through improved thermal breaks and air baffles, while also providing for structural and aesthetic requirements.

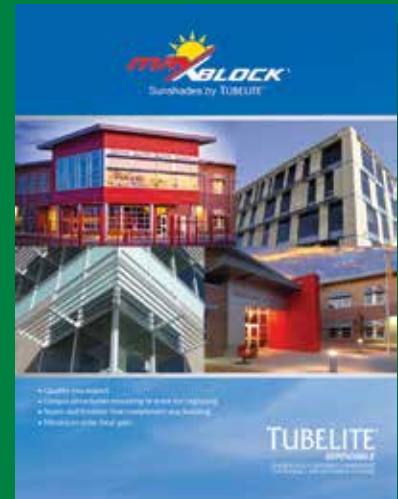

MaxBlock® Sunshades

MaxBlock brochure includes Tubelite's three sun shade designs, Airfoil, "Z" Blade and Tubular, along with highlighting the benefits of these sun shades.

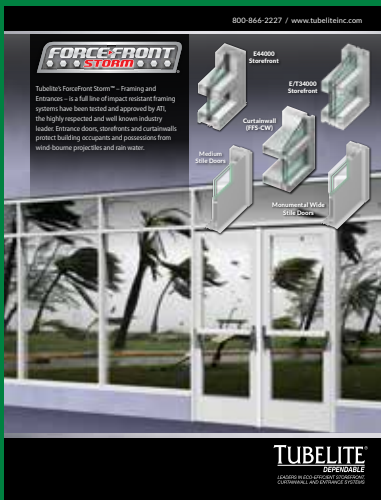

ForceFront Storm® – Framing and Entrances

ForceFront Storm® – Framing and Entrances – is a full line of impact resistant framing systems have been tested and approved by ATI, the highly respected and well known industry leader.



ForceFront Blast® – Framing and Entrances

ForceFront Blast® – Framing and Entrances – pressure bar curtainwall framing and wide stile monumental doors are designed for compliance with ASTM, GSA ISC and DoD requirements.



aLuminate® Light Shelves

aLuminate light shelves are designed for use with most Tubelite storefront and curtainwall framing systems, as well as many other aluminum framing systems.

TUBELITE®
DEPENDABLE
 LEADERS IN ECO-EFFICIENT STOREFRONT, CURTAINWALL AND ENTRANCE SYSTEMS